

Design Patent Quick Facts

Design Patents:

- Are useful to protect the design of **nearly every type of product** from smartphones to the retail stores that sell them; from pharmaceuticals to medical devices; and from running shoes to construction equipment
- Can be used to protect an **entire product or just part of it**
- Protection in the U.S. **runs 15 years** from the grant date
- Issued U.S. design patents more than doubled from 2014 to 2024; in the U.S., **issued design patents jumped 33% 2023 to 2024**
- Are complimentary to utility patents; **utility patents** protect the **way a product works**, **design patents** protect the **way a product looks**
- Can be **filed as a continuation** of a pending utility patent application
- Unlike utility patents, **can only contain one claim**
- Are typically **less costly**, and **easier and quicker to obtain** than utility patents; in some jurisdictions design rights can be **obtained in a matter of days**
- Must be filed abroad **within 6 months** of the U.S. filing date to claim Paris Convention priority
- Can be efficiently filed around the world using WIPO's Hague international design system

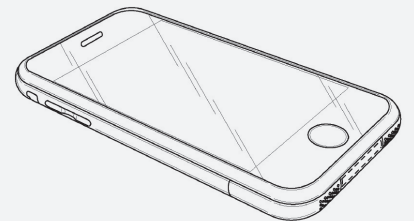

smart phone

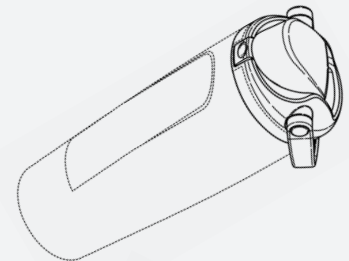

water bottle

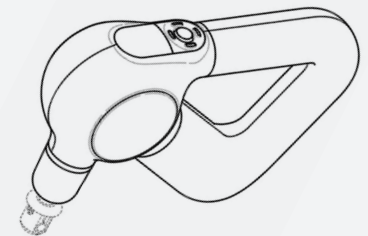

massage device

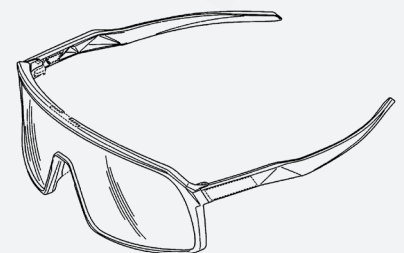

sunglasses

Design patents:

- Have a **unique remedy for infringement in the U.S.:** disgorgement of the infringer's total profit; one of the largest U.S. patent infringement awards was based almost exclusively on design patents
- Can be **simpler and easier to prove infringement**, often causing infringers to stop selling an infringing product with just receipt of a demand letter
- Are **accepted by some online sales platforms** for takedown of infringing products
- **Outperform utility patents in obtaining injunctions**, both in district court and at the ITC, including general exclusion orders (more than 50% of investigations between 2015 and 2024 involving a design patent granted a GEO)
- Are less often the basis for a successful institution in an IPR or PGR at the USPTO than utility patents; **<40% institution rate (2013 - 2025)**
- Are **complimentary to trademark/trade dress rights**, but are **not subject to limitations** like use in commerce or source identification
- Are **complimentary to copyright**, but are **not subject to limitations** like creativity, fair use, or independent creation

For more information, please visit the **design patents page on our website** or contact Director, Tracy Durkin at tdurkin@sternekessler.com.

[sternekessler.com](https://www.sterneessler.com)

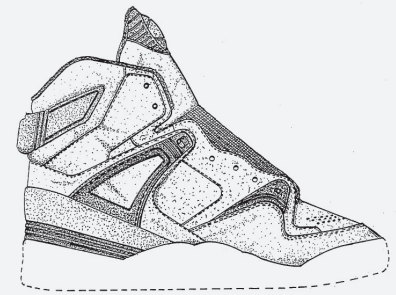

shoe upper

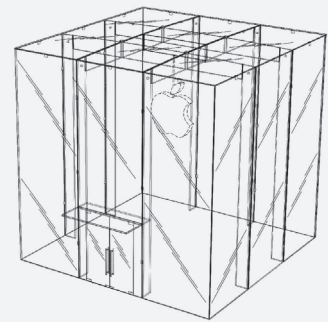

building

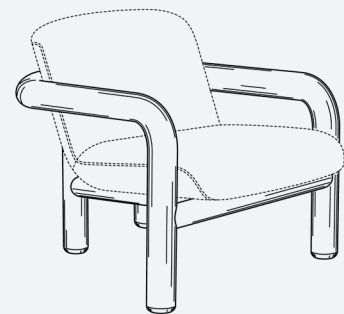

chair



graphical user interface (GUI)